

# Block 14

Julie Comstock™

## Supplies & Cutting

**Dark:** (9" x 11")

*cut carefully, you will be using 8" of the 9" wide strip*

1-3<sup>7</sup>/<sub>8</sub>" x 11" strip

cut the 1 strip into 2-3<sup>7</sup>/<sub>8</sub>" x 3<sup>7</sup>/<sub>8</sub>" squares

cut the 2 squares once on the diagonal to make 4 triangles

1-2" x 11" strip

cut the 1 strip into 4-2" x 2" squares

**Medium:** (9" x 11")

2-3<sup>1</sup>/<sub>2</sub>" x 11" strips

cut the 2 strips into 4-3<sup>1</sup>/<sub>2</sub>" x 3<sup>1</sup>/<sub>2</sub>" squares

**Light:** (9" x 11")

1-2<sup>3</sup>/<sub>8</sub>" x 11" strip

cut the 1 strip into 4-2<sup>3</sup>/<sub>8</sub>" x 2<sup>3</sup>/<sub>8</sub>" squares

cut the 4 squares once of the diagonal to make 8 triangles

1-3<sup>1</sup>/<sub>2</sub>" x 3<sup>1</sup>/<sub>2</sub>" square

Use a 1/4" seam allowance.

Press in the direction of the arrows.

## Quilt Construction

- (A) Sew 1-2<sup>3</sup>/<sub>8</sub>" Light triangle to each side of 1-2" x 2" Dark square. Make 4.

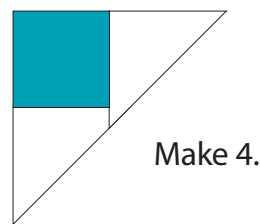
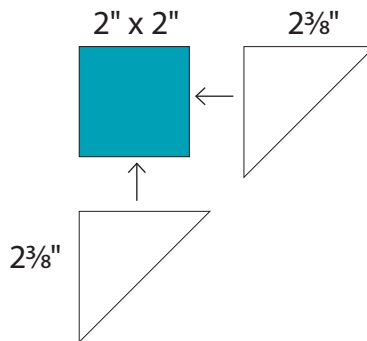

- (B) Add 1-3<sup>7</sup>/<sub>8</sub>" Dark triangle to the previous unit. Make 4.

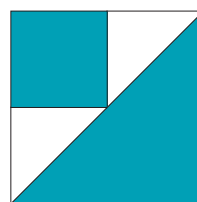
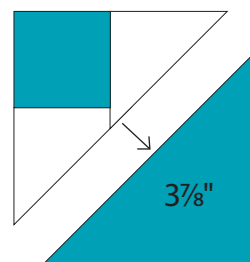

Corners  
Make 4.

3<sup>1</sup>/<sub>2</sub>" x 3<sup>1</sup>/<sub>2</sub>" with seams

2 Assembly: Sew the block parts into rows as shown. Press in the direction of the arrows. Combine the rows.

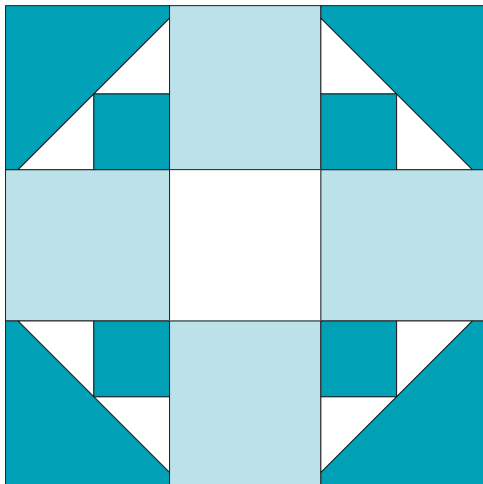
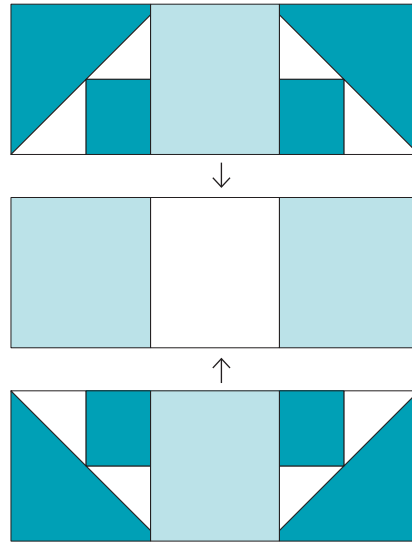
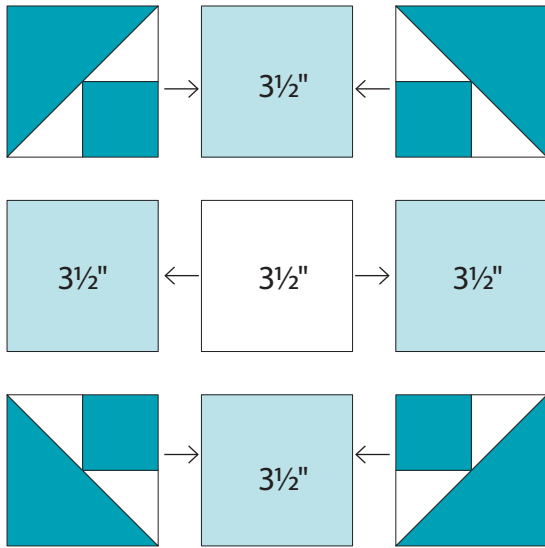

9 1/2" x 9 1/2" with seams